

Complete Assembly Testing and Run-Off

Modern assembly bays have the capacity for very large machine configurations. (We've assembled and run-off systems more than 156 feet in length.)

Technicians who are true craftsmen, from electrical and control work to tooling and final part run-off, carefully monitor and certify each stage of the machine's assembly.

We stock many long-lead-time machine components so production schedules can be tailored to meet your delivery requirements.

Engineered with Your Application in Mind

Industries Served:

- Motor vehicles
- Transportation equipment
- Power transmission equipment
- Construction equipment
- Fluid power products
- Oil country equipment and components
- Mining equipment
- Aircraft
- Machine tools

Typical Parts:

- Transmission and steering parts, axles, drive shafts and spacers
- Cylinder bodies, piston rods, couplings and fittings
- Piston rings, bearing spacers, gear blanks and hubs
- Pins, shafts and guide rods



Materials:

- Cast iron
- Stainless steel
- Carbon steel
- Alloys
- Aluminum

Bardons & Oliver Cut-Off Lathes chamfer, groove and cut off in one setup to optimize production on any job, large or small. A full line of standard and special attachments will help you produce a wide variety of parts quickly and accurately.

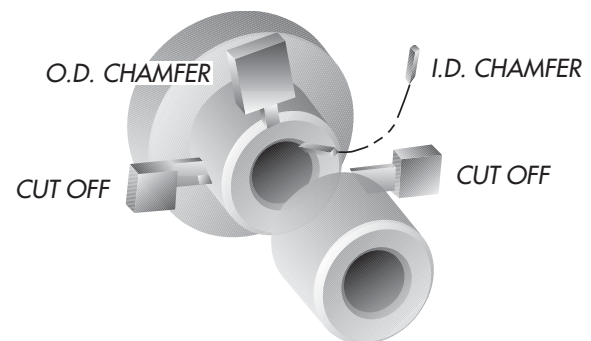
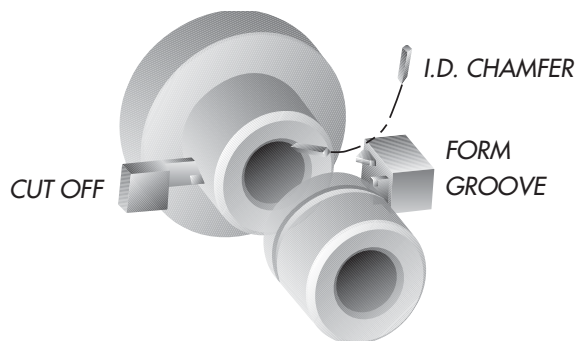

Model 34 and 36 Cut-Off Slides can be configured to machine independently or synchronized together for parts such as these.

Bardons & Oliver Cut-Off Lathes Offer Features That Reduce Setup Time, Produce Parts Faster and Require Less Maintenance

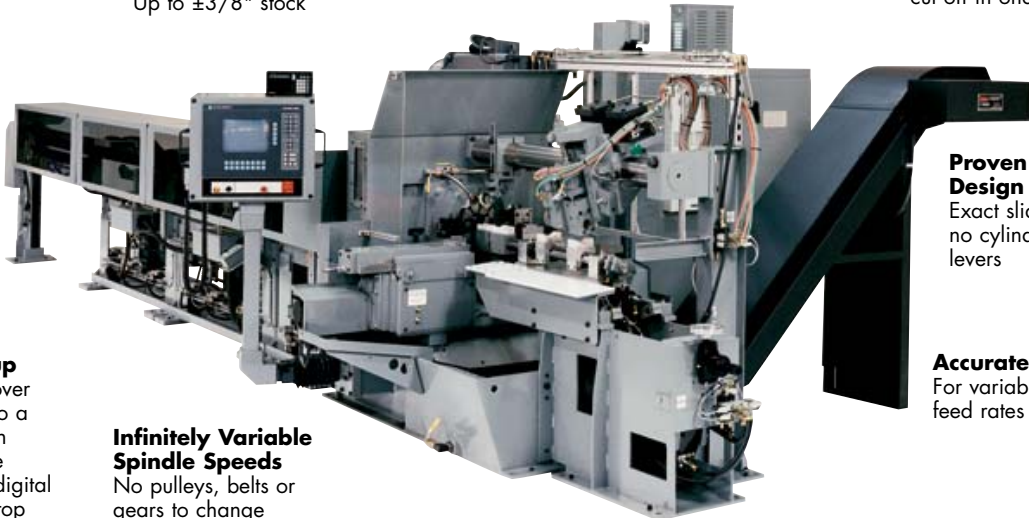

Maximum Power
15 to 30 HP

Extended Range Collet
Up to $\pm 3/8$ " stock

Industry-Leading Capacity
4", 5-1/2", 7" or 8" tubing; up to 3" bar

Unmatched Versatility
Chamfer, form, groove and cut off in one setup

Unique Key Pad Entry
Fast programming of the cut-off and overhead slide rapid advance, feed start and return position

Proven Ball Screw Design
Exact slide positioning—no cylinders, links or levers

Faster Setup
Part changeover time is kept to a minimum with quick change collet pads, digital readout on stop

Accurate Servo Motors
For variable cut-off slide feed rates

Infinitely Variable Spindle Speeds
No pulleys, belts or gears to change

Programmable Controller
State-of-the-art technology combined with user-friendly menus and part program storage capability

Tooling
Versatile selection of chamfer, form and grooving tools, which are accessible and easy to change

Experience and Know-How Mean Maximum Productivity and Uptime

Quality design, rugged construction and over a century of learning the best way to do things has helped make our cut-off machines easy to use and service.

Attention to detail is what, in the long run, adds up to the ability to perform a variety of jobs well, for an extended period of time, with only a minimum of required maintenance.

- Positive spray lubrication of head stock bearings and gears.
- Fingerless collet mechanism eliminates rollers and pins.
- Rugged ball screw driven slides eliminate hydraulic pump, valves, controls and cylinders.
- The entire chip area is open to allow for easier chip removal and transfer of cut parts. The chip pan is separate from the machine and may be easily modified to accept chip conveyors or in-the-floor removal systems.

Cut-Off Lathes So Versatile Maybe You Should Use Them for More Than Cutting Off

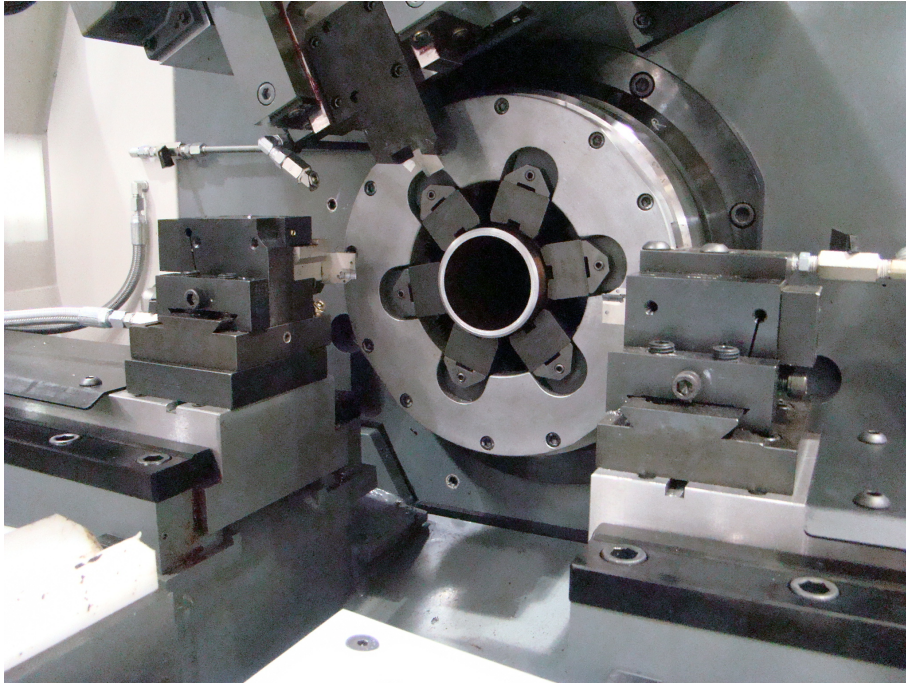

Easy access tool area makes adding attachments or changing tools a simple task.



ID chamfer unit is used for deburring and chamfering.

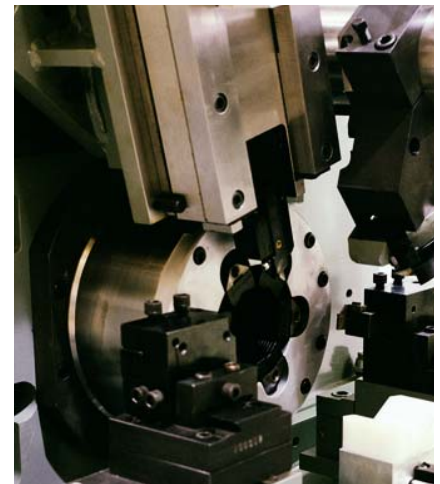

OD chamfer attachment can be tooled to chamfer, radius and form the OD of tubing or bar stock.

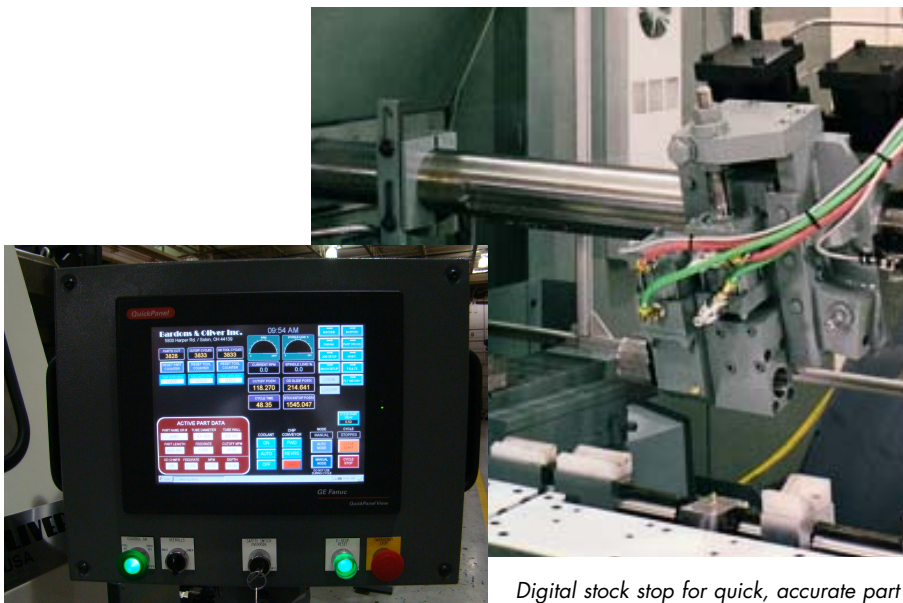

Digital stock stop for quick, accurate part length change.

A Wide Range of Standard and Special Attachments Can Accomplish a Variety of Tasks

- ID chamfer unit
- OD chamfer attachment
- Digital stock stop
- Chip conveyors
- Carbide cut-off tool holders
- Saw cut-off attachment
- Roller cut-off attachment
- Special collets

Bardons & Oliver: The Acknowledged Industry Leader in Loading and Unloading Technology.

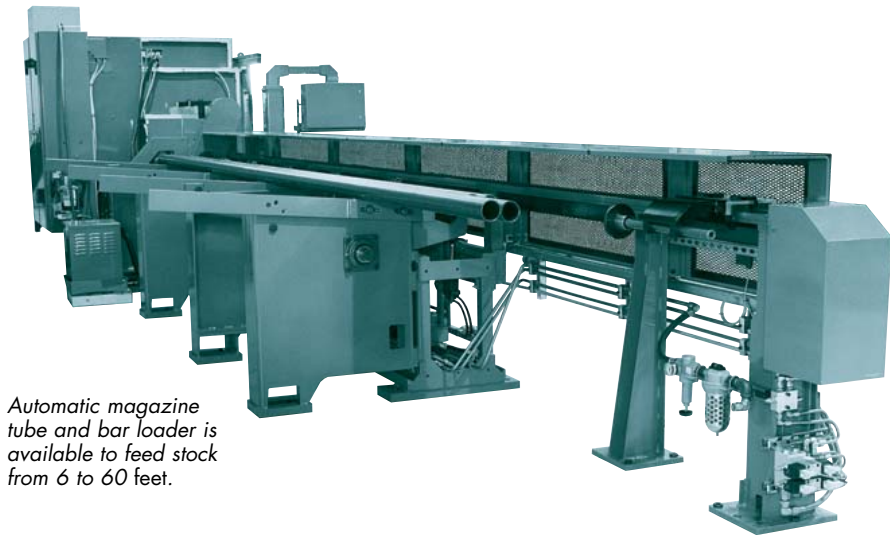

Automatic magazine tube and bar loader is available to feed stock from 6 to 60 feet.

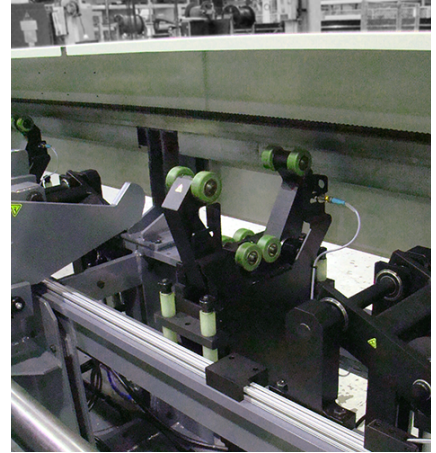

Long tubes and bars are supported with the loading table steady rest system. No adjustment is required for different stock diameters.

Automatic Loading Maximizes Productivity

Proper handling is the key factor that separates Bardons & Oliver cut-off lathes from the competition.

Automatic loading tables keep stock in the machines at all times, which lets one operator run more than one machine. All handling equipment is designed with unitized construction, so it can be easily modified to meet your specific requirements.

The loading table loads one length of material after another into the machine and then automatically crops a pre-determined amount off the leading end and ejects the remnant end.

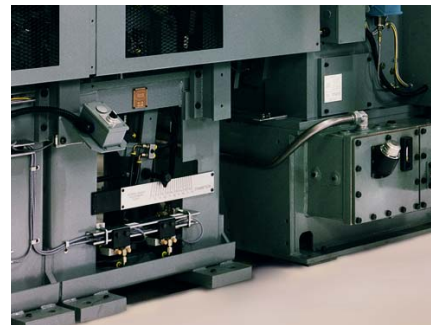

Stock diameter changeover is fast and easy with our electric screw-driven height adjustment.

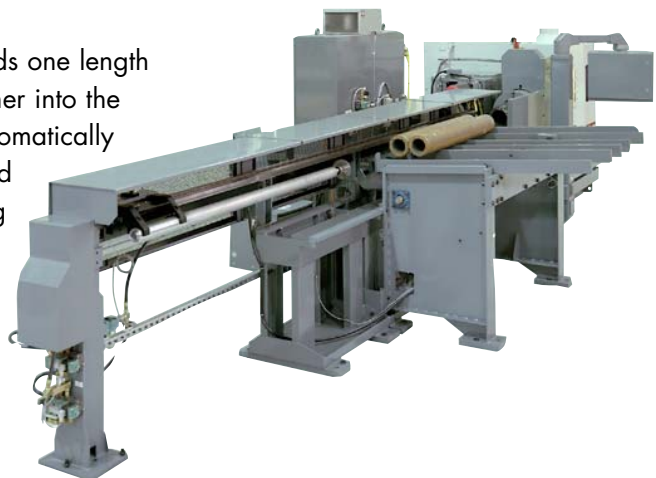

Automatic, Reliable Unloading Maximizes Throughput

Proper handling from start to finish is assured with a choice of unloading systems to fit your particular application.

The pivot-type unloader handles short parts (6" to 48" lengths). After supporting the piece during cut off, the pivot arm retracts and drops down to unload the part.

Longer lengths can be supported during cut-off by the steady rest arrangement shown here. After cut off, the entire carriage moves away and discharges the cut pieces for easy operator access.

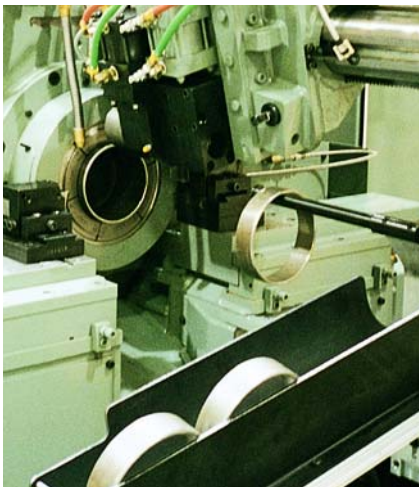

Unloading short parts is a "no-problem" operation with this pick-off arm arrangement.

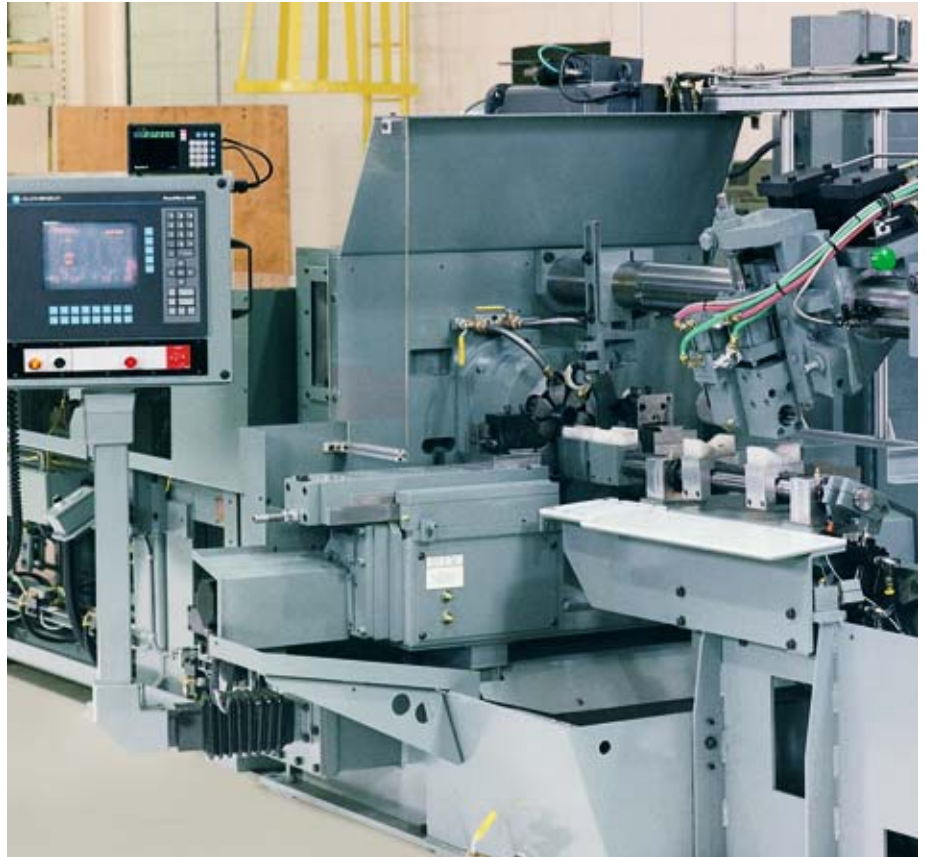

Medium-length parts are handled efficiently with the unique pivot arm unloading system.

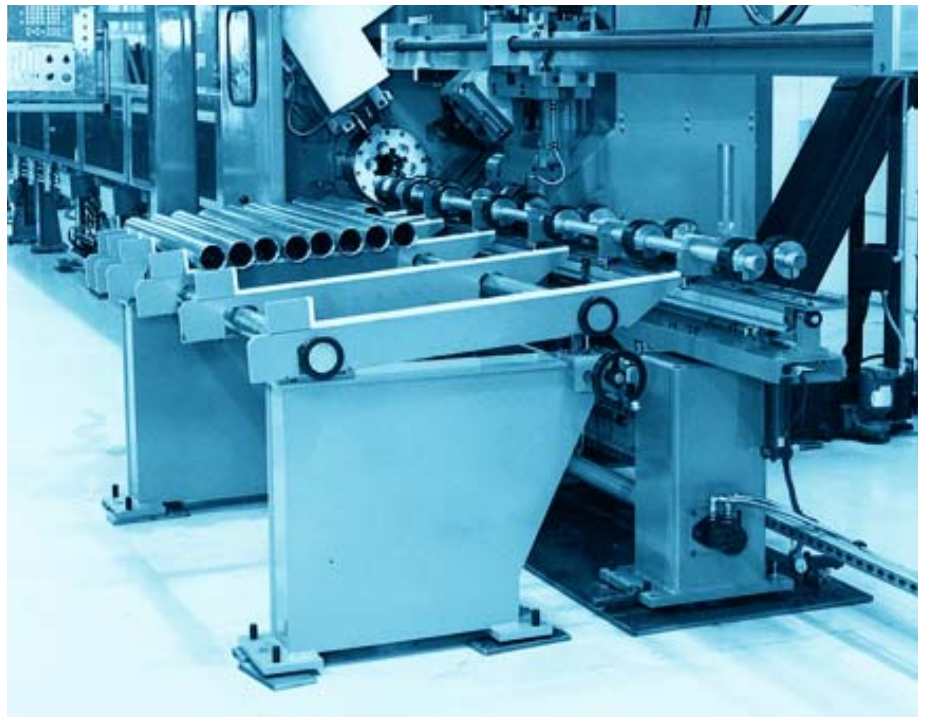

Long parts get all the support they need during cut off and unloading with this steady rest system.

SPECIFICATIONS

No. 34 Automatic Cut-Off Lathe

Spindle

Maximum collet capacity diameter3", 4", 4-1/2"
Speeds—infinately variableto 1500 RPM
Maximum opening for collet on diameter3/8"

Cut-Off Slides

Maximum travel3-1/2"
Width6-1/4"
Center of spindle to top of slides4"

Stock Stop

Standard maximum part cut-off length36"
Optional maximum part cut-off length12'

Motor

AC variable speed15HP

Floor Space (approx.)

Machine66" x 114"
Electrical Box36" x 36"
Weight (approx.)6,600 lbs.

No. 36 Automatic Cut-Off Lathe

Spindle

Maximum collet capacity diameter5-1/2", 7", 8"
Speeds—infinately variableto 1300 RPM
Maximum opening for collet on diameter5/8"

Cut-Off Slides

Maximum travel4"
Width8-1/2"
Center of spindle to top of slides5-5/8"

Stock Stop

Standard maximum part cut-off length33"
Optional maximum part cut-off length12'

Motor

AC variable speed30HP

Floor Space (approx.)

Machine57" x 111"
Electrical Box36" x 36"
Weight (approx.)12,000 lbs.



Bardons & Oliver also offers a CNC lathe (Model 36TBC) that turns, bores, faces, threads, profiles and cuts off automatically.

BARDONS & OLIVER

5800 Harper Road
Solon, Ohio 44139
(216) 498-5800
Fax: (216) 498-2001
Internet: www.bardonsoliver.com
E-Mail: information@bardonsoliver.com

Specifications subject to change without notice.
© 2013, Bardons & Oliver, Inc.